

SPECIFICATION



90t



47.5m



65.5m

SRC900T

SANY ROUGH TERRAIN CRANE

QUALITY CHANGES THE WORLD

crane.sanyglobal.com

It is one of the core business units in SANY Group, specializing in the development and manufacturing of high-end wheel cranes, crawler cranes and tower cranes, including the complete range of wheel cranes from 8 to 1800t, crawler cranes from 25 to 4500t and tower cranes from 6 to 185t.

三一集团旗下核心事业部，从事高端轮式起重机、履带起重机、塔式起重机系列产品的研发制造。覆盖8-1800吨全吨位轮式起重机，25-4500吨全吨位履带起重机，6-185吨塔式起重机。



SANY CRANE



SRC900T

SANY ROUGH TERRAIN CRANE
90T LIFTING CAPACITY

A 90t rough terrain crane with five section 47.5m boom, featuring stronger capacity. Key components come from International name brands. Operator comfort is improved by brand new cab design.

最大起重量90吨，5节臂，最大主臂长47.5m的越野起重机，性能强，核心部件均为国际知名供应商提供，配备全新操纵室，驾驶、操作舒适度全面升级。





Strong lifting capacity

Best in class

超强性能

性能超越行业同吨位

All new operator's cab

Ergonomic concept of safety and comfort

全新操纵室

操作安全、舒适、人机工程全面升级

Convenient transport

One-trailer transport at low operational cost

超便捷运输

一车整运，运营成本低

Brand-name components

DF Cummins engine/Dana transmission

国际知名供应商

东风康明斯发动机/德纳变速箱



All New Operator's Cab

全新操纵室

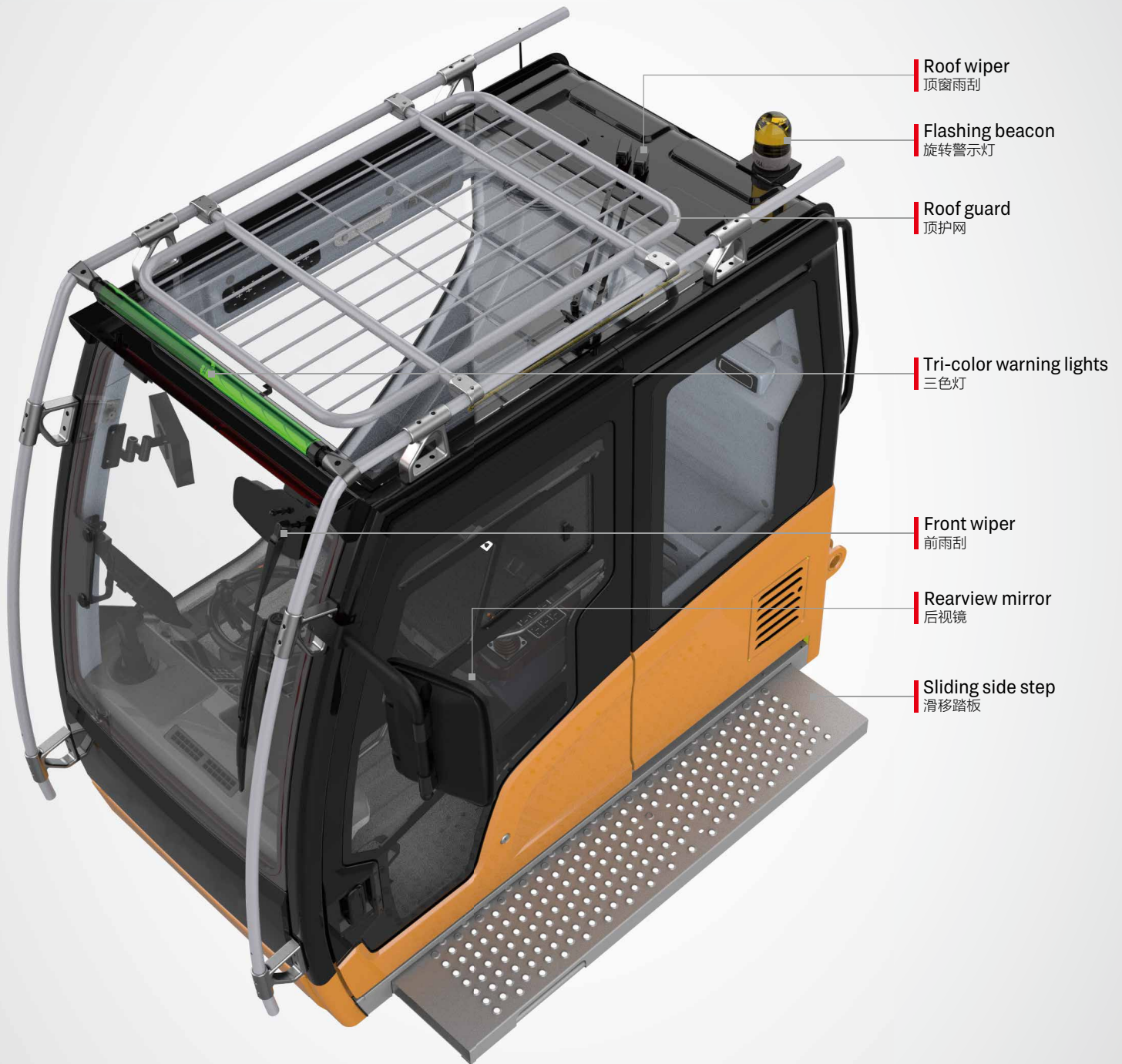

Roof wiper
顶窗雨刮

Flashing beacon
旋转警示灯

Roof guard
顶护网

Tri-color warning lights
三色灯

Front wiper
前雨刮

Rearview mirror
后视镜

Sliding side step
滑移踏板



Safety & Reliability
安全可靠



Comfort & Convenience
舒适便捷



Simplicity & Efficiency
简单高效

SPECIFICATION

Rearview and
winch monitor
卷扬监视器

10.1 inch LMI screen
10.1 吋显示屏

Outrigger control
panel
支腿控制面板

Steering column
方向柱

Pedals
踏板布置

Upper control panel
辅助面板

Emergency stop
switch
急停开关

Bubble level
水平仪

Cup holder
水杯托

Joystick
手柄

Joystick
手柄

Left control panel
左扶手箱控制面板

Right control panel &
LMI navigation knob
右扶手箱控制面板

Armrest
扶手箱

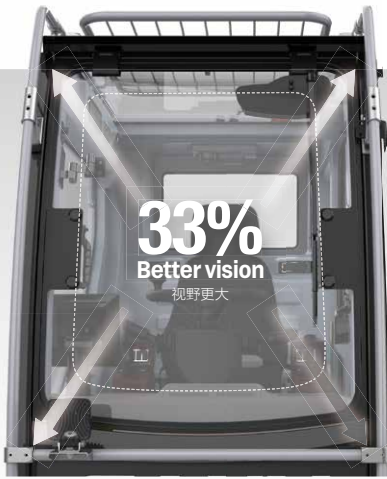

Integrating SUV genes, overall space is enlarged by 10% and forward field of vision is increased by 33%. The front windshield can be opened by 70 degrees, providing better ventilation and a second emergency exit.

融入 SUV 基因, 整体空间增大 10%, 配备超大可开合 70° 前挡风玻璃, 视野提升 33%, 增加空气对流, 并可作为快速逃生通道。



Sliding door transits between tracks when closing to make perfect thermal and acoustical insulation.

侧向变轨, 滑移门完美隔绝外部环境。

Getting in and out is made more convenient with the power sliding side step.

全宽电动伸缩踏板, 超大安全便利进出通道。

SPECIFICATION

Adjustable steering wheel for driving and controlling, modular control panels, and smart user interface deliver intuitive and highly efficient control.

驾控一体的方向盘、模块化控制面板、UI 智能操作界面，操作简单，为高效吊装保驾护航。



Convenient Transport

行驶运输便捷性

Four steering modes

四种转向模型

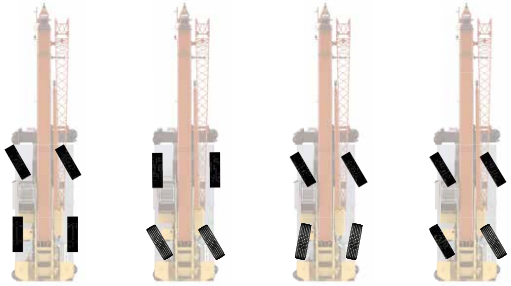

2 wheel front 前轮转向模式

2 wheel rear 后轮转向模式

4 wheel 四轮转向模式

Crab 蟹行模式



Steering control panel
转向控制面板

One-Trailer Transport

一车整运

The basic machine is transported at 52t with counterweight, jib and hooks, 3.34m wide and 3.83m high, satisfying road regulations.

主机运输尺寸为宽 3.34m, 高 3.83m, 重量为 52t (带配重、副臂和吊钩), 满足道路运输要求。

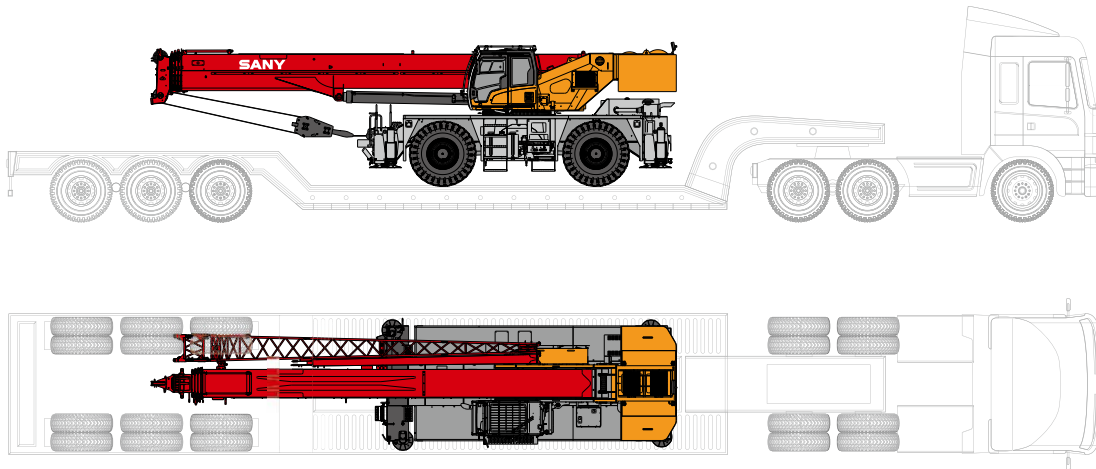

Axle Load Distribution

轴荷分布

Items 项目	Weight (kg) 重量	Load on front axle (kg) 前轴轴荷	Load on rear axle (kg) 后轴轴荷
Basic machine 主机	52000	27500	24500
Counterweight 配重	9000	-3000	12000
Fixed jib 副臂	1100	1800	-700
Aux. boom nose 臂尖滑轮	50	150	-100
Main hook 主钩	70t	690	-1270
Auxiliary hook 副钩	8t	160	-80

Note: boom angle remains 0°
起重臂角度 0°

Carrier Frame

车架底盘



Inverted trapezoidal variable cross section frame is 5% less in weight and 10% stronger in rigidity.

倒梯形变截面车架, 实现车架减重 5% 的同时, 刚性提升 10%。

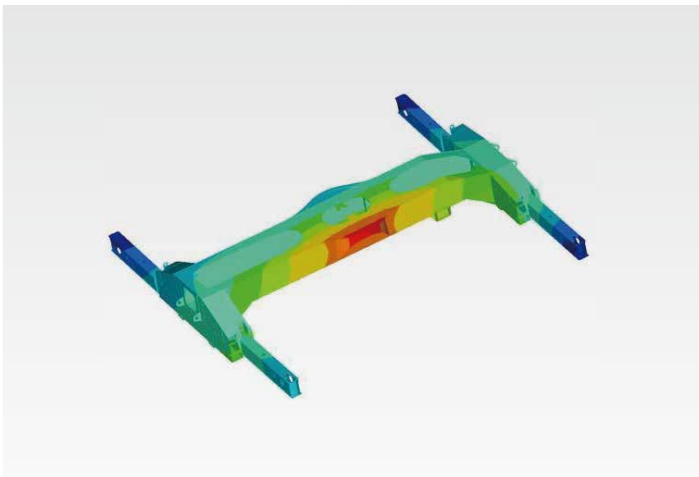

↓ 5%
Weight 重量

↑ 10%
Rigidity 刚性

Power Train

动力系统

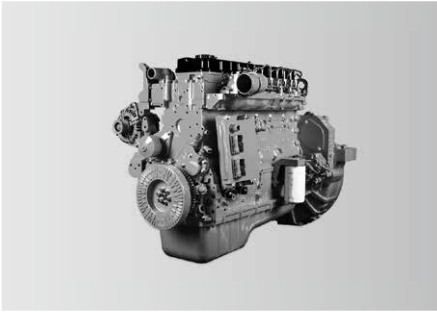

Engine

Power comes from a DF Cummins QSB6.7 inline six-cylinder water-cooled, turbocharged and intercooled off-highway diesel engine, complying with Stage III emission standard.
 Rated power: 194kW/2400rpm.
 Max. torque: 990N·m/1500rpm.

发动机

东风康明斯 QSB6.7 三阶段非道路直列六缸水冷、增压中冷柴油发动机。
 额定功率 :194kW/2400rpm。
 最大扭矩 :990N·m/1500rpm。

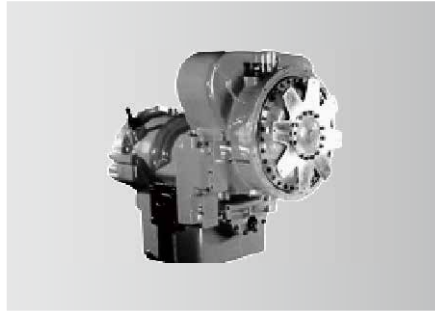

Transmission

Dana electronically controlled auto transmission features 6 speeds forward and 6 speeds reverse, wide ratio range, and smooth gearshift with reduced maintenance cost.

变速箱

德纳全自动电控变速箱,6个前进挡、6个后退挡,速比范围大,换挡平顺无冲击,维修保养成本低。

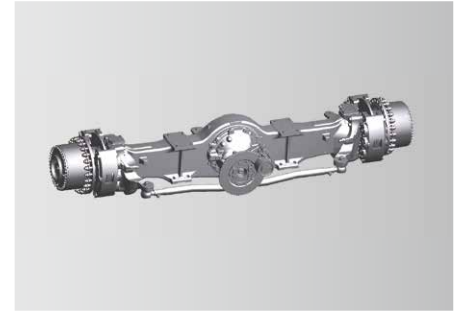

Axle and suspension

Both axles are driven and steered. Front axle is mounted to the frame by independent steel plate, and rear adopts oscillation cylinders with hydraulic lockout. Driving comfort and lateral stability is therefore guaranteed on rough terrains and conditions.

车桥悬挂

前后桥均为驱动桥和转向桥。前桥采用独立式钢板连接,后桥采用摆动支架式,液压油缸闭锁悬架系统;能适用各种恶劣工况和路面,保证车辆行驶的平顺性和侧翻稳定性,驾驶舒适。

Electrical System

电气系统

Smart CAN-BUS communication system

International advanced CAN-BUS data communication network applied for display, instrument panel, I/O module, joysticks and main sensors, allowing for high-speed data transmission and quick response in less than 20ms.

Winch camera (optional)

Winch cameras equipped for monitoring its working condition and identifying rope disorder in time.

Integrated bus button panel input

Various operating states displayed by button indicator lights, and one-button multi-functional operation realizable by writing various operation modes.

智能总线通信系统

国际先进的分布式集成总线数据通信网络，显示器、显示仪表、I/O 模块、操作手柄、主要传感器等采用 CAN 总线组网，高速信息传输、响应速度小于 20ms。

卷扬监控系统(选配)

卷扬摄像头监视卷扬工作及及时发现乱绳的情况。

集成总线按键面板输入

可通过按键指示灯显示各种工作状态，通过写入多种操作模式实现一键多功能。



Centralized electric cabinet
集中式电控箱



Anti-two-block switch
高度限位器



Third wrap indicator
三圈保护器



Cable reel
电缆卷筒



Anemometer
风速仪

Multi-functional screen

Large 10.1 inch HD touch screen display with all new interface. Incorporated crane setup, load charts, working conditions, working period, virtual wall, Bluetooth, radio and diagnostics with an additional navigation knob.

Precise load moment indicator

SANY independently developed LMI, accuracy of 0 ~ 5%.

高新多功能显示屏

采用 10.1 寸高清显示屏, 全新操作界面, 可实现触摸与旋钮多种方式操控。工况、力矩、发动机、变速箱、控制器 IO 点、工作时间统计等丰富的设备状态信息呈现, 集成虚拟墙、蓝牙、收音机等多种扩展功能。

精准力矩器系统

三一自主研发的力矩限制器系统, 精度达 0~5%。

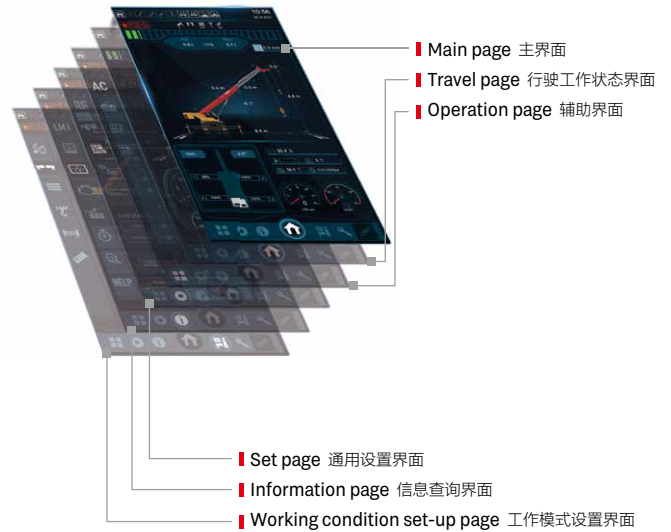

MachineLink⁺

ROOTCLOUD T-AMS Pro device comes as standard to realize GPS trajectory, machine status, maintenance management, E-fence, alarm management, and operator management on computer or mobile MachineLink+ platform, by remote control of cranes. This telematics package greatly boosts efficiency of customer fleet management and helps provide better after-sales services.

标配树根物联终端 T-AMS Pro, 通过对起重机设备的远程控制, 在电脑或移动端 MachineLink+ 平台实现轨迹回放、设备状态、维保设备、电子围栏、报警管理、操作手管理等功能, 极大提高客户设备管理效率, 提升三一售后服务能力。

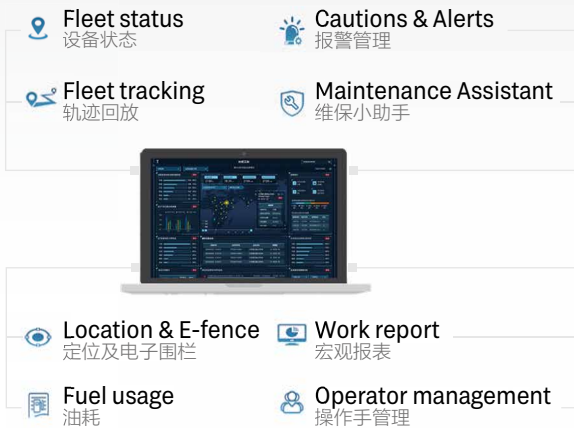

Hydraulic System

液压系统

Four boom sections extended by double cylinder with rope arranger, 2nd boom extended by cylinder I, 3rd ~5th sections telescoped by cylinder II with rope pull. Synchronized telescoping of variable lengths for more applications with higher efficiency.

5 节主臂，双缸绳排，一节油缸和钢丝绳伸 2 节臂，2 节油缸和钢丝绳伸 3、4、5 节臂，可实现同步伸缩，臂长任意组合，省时省力。



Telescoping mode I
伸缩模式 1

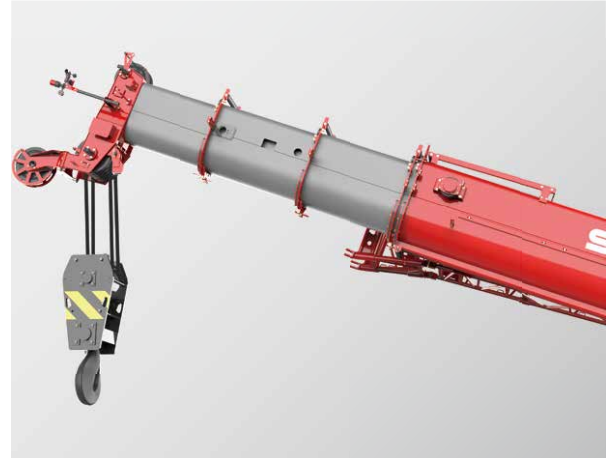

Telescoping mode II
伸缩模式 2

Superstructure

上车

Open-type electronically controlled load-sensing system and dynamic slewing brake system.

Electro proportional compensated passive luffing-down system applied to control the luffing speed, making luffing more reliable and stable.

Dynamic slewing brake realizing precise control of slewing speed.

Electronically controlled load-sensing hydraulic system, electronic joystick and electronic throttle, ensuring easy operation and more accurate control and millisecond-level action response speed, with min. single-rope hoisting speed 0.8m/min, and distribution difference in case of combined motions 8%.

通过开式电控负载敏感系统和动态回转制动系统；

电比例自重落幅系统控制落幅速度，更可靠更平稳；

具备动态回转制动功能，可实现回转速度精准控制；

电控负载敏感液压系统，采用电手柄、电油门控制，轻松操作的同时，控制更精准；动作响应毫秒级速度；卷扬单绳最低速度 0.8m/min；复合动作分配误差 8%。

Chassis

下车

Steering system

A gear pump installed to supply oil for hydraulic steering, steering pressure controlled by electro-proportional relief valve, four steering modes realized by solenoid directional valve.

Suspension system

Different modes including normal driving and Pick & Carry with suspension locked, suspension to be locked when the crane is working.

Outrigger telescoping system

The electro proportional relief valve identifies pressure staging of outrigger telescoping, satisfying operation requirements under high pressure and forming protection under limited pressure.

转向系统

液压转向系统采用齿轮泵提供油源,通过电比例溢流阀精确控制转向压力,通过电磁换向阀实现前轮转向,后轮转向,全轮转向和蟹行转向共计四种转向模式。

悬挂系统

悬挂系统通过选择不同的悬挂模式可以实现正常行驶和锁定模式下的带载行驶;在起重机上车作业时能够对悬挂进行锁定。

支腿伸缩系统

支腿伸缩采用电比例溢流阀对支腿伸缩进行压力分级,既满足高压力动作需求,也可满足限压保护功能。

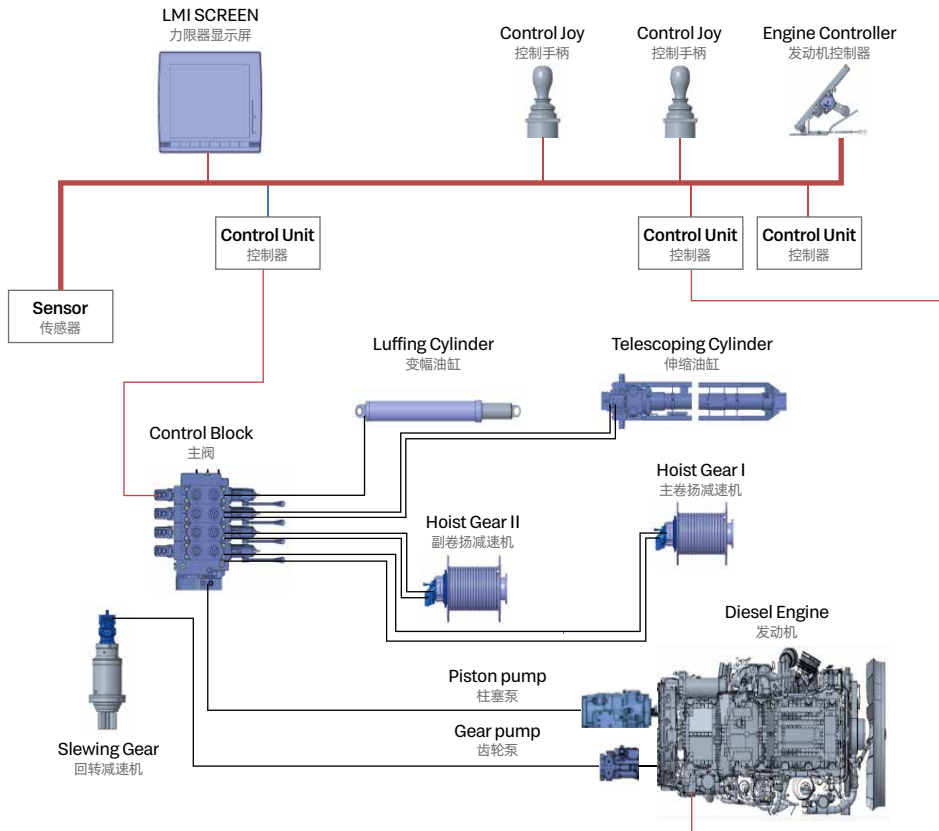

Overall Dimensions

整机尺寸

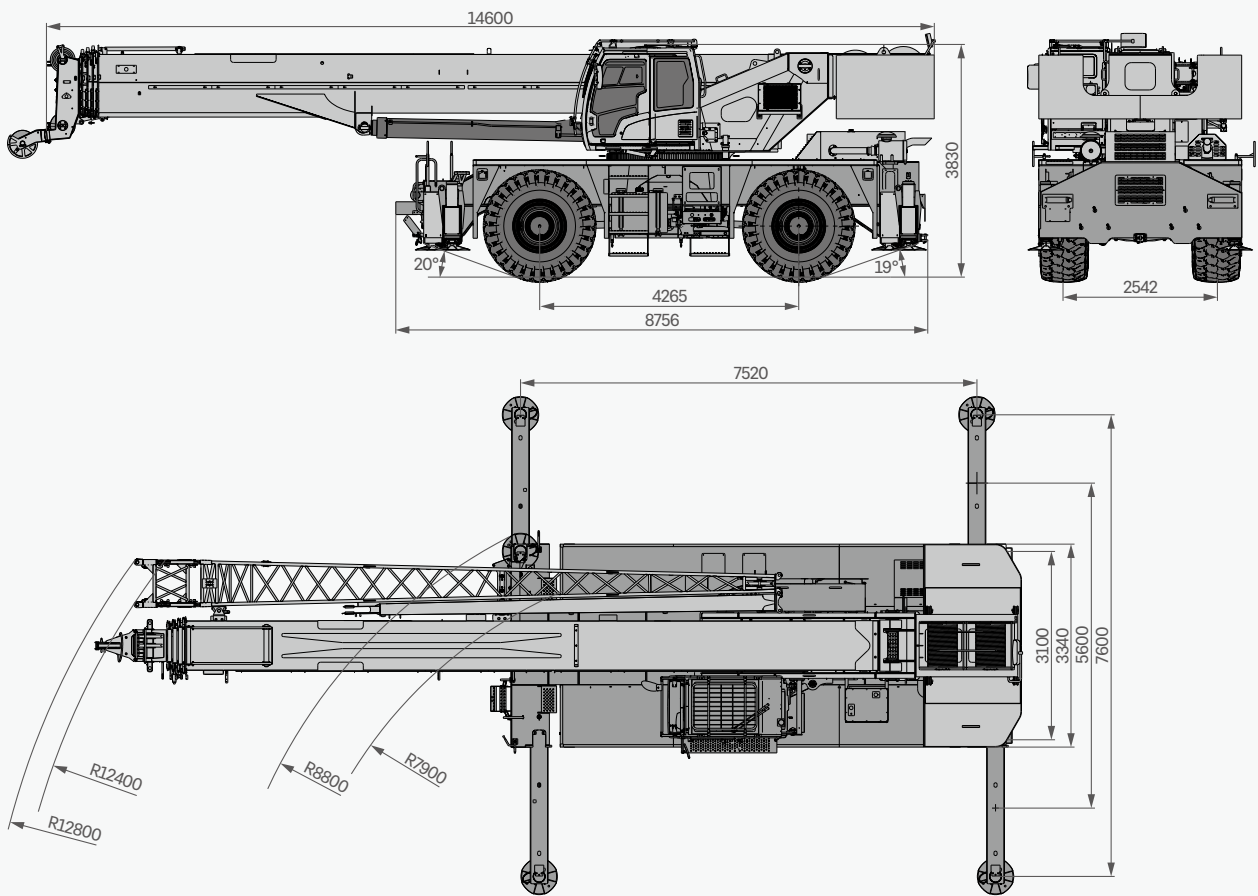

Technical Specification

整机参数

CATEGORY 类型	ITEM 项目	UNIT 单位	VALUE 参数	
CAPACITY 额定起重量	Max. lifting capacity 最大起重量	t	90	
WEIGHT 重量参数	Gross weight 整机总质量	kg	52000	
POWER 发动机参数	Engine model 发动机型号	-	QSB6.7 (Tier III)	
	Max. engine power 发动机最大功率	kW/rpm	194/2400	
	Max. engine torque 发动机最大输出扭矩	N·m/rpm	990/1500	
DIMENSIONS 尺寸参数	Overall length 整机全长	mm	14600	
	Overall width 整机全宽	mm	3340	
	Overall height 整机全高	mm	3830	
TRAVEL 行驶参数	Max. travel speed 最高行驶速度	km/h	36	
	Min. steering radius 最小转弯半径	m	14.1/7.9	
	Wheel formula 车轮模式	-	4 × 2; 4 × 4	
	Min. ground clearance 最小离地间隙	mm	530	
	Approach angle 接近角	°	20	
	Departure angle 离去角	°	19	
	Max. gradeability 最大爬坡度	-	75%	
	Fuel consumption per 100km 每 100 公里油耗	L	115	
MAIN PERFORMANCE 主要性能参数	Working temperature range 使用温度区间	°C	-20~ +45	
	Min. rated lifting radius 最小额定幅度	m	2.5	
	Tail slewing radius 转台尾部回转半径	mm	4.5	
	Boom sections (Qty.) 臂节数	-	5	
	Boom shape 臂形状	-	U shape U 型	
	Max. lifting moment 最大起重力矩	Basic boom 基本臂	kN·m	2734
		Full-extension boom 全伸主臂	kN·m	1481
		Full-extension boom + jib 全伸主臂 + 副臂	kN·m	730
	Boom length 臂长	Basic boom 基本臂	m	12.2
		Full-extension boom 全伸主臂	m	47.5
		Full-extension boom + jib 全伸主臂 + 副臂	m	65
	Max. lifting height 最大起重高度	Basic boom 基本臂	m	13
		Full-extension boom 全伸主臂	m	48
Full-extension boom + jib 全伸主臂 + 副臂		m	65.5	
Outrigger span (Longitudinal × Transverse) 支腿跨距 (纵 × 横)	m	7.52 × 7.6		
Jib offset 副臂安装角度	°	0, 15, 30		
AIRCONDITIONER 空调	In operator's cab 上车空调	-	Heating & cooling 制冷、制热	

Technical Specification

整机参数



Axle Load 轴荷

Axle 轴	1	2	Gross weight 总重量
Axle load 轴荷 /kg	27500	24500	52000
Remark 备注	Boom angle 0°, with full water and fuel reservoirs, main hook, aux hook. 起重臂角度 0°、满水、满油、主钩、副钩吊臂头		



Hook 吊钩

Rated load 额载 /t	Number of sheaves 滑轮数量	Rope rate 倍率	Hook weight/kg 吊钩重量
70	5	10	690
8	-	1	160



Operations 主要动作参数

Item 项目	Max. single rope lifting speed (empty load) 单绳速度 (空载)	Rope diameter/length 钢丝绳直径 / 长度	Max. single line pull 最大单绳拉力
Main winch 主卷扬	150m/min	20mm/250m	8.3t
Auxiliary winch 副卷扬	150m/min	20mm/145m	8.3t
Slewing speed 回转速度	1.8r/min		
Full luffing up/down time of boom 主臂起落幅时间	80s/85s		
Full extension/retraction time of boom 主臂伸缩时间	120s/125s		
Outrigger jack 垂直支腿	Extension 伸	40s	
	Retraction 缩	30s	
Outrigger beam 水平支腿	Extension 伸	20s	
	Retraction 缩	15s	

Crane Introduction

整机介绍

Carrier 下车

Carrier frame 车架

- Double longitudinal beam construction welded by high strength steel plate, higher bearing capacity.
- 车架为高强度钢板焊接而成的双纵梁结构，承载能力强。

Engine 发动机

- Model: DF Cummins QSB6.7 inline six-cylinder diesel engine with watercooler and inter cooler.
- Rate power: 194kW/2400rpm.
- Emission standard: Tier III.
- Fuel reservoir capacity: 350L.
- 型号：东风康明斯 QSB6.7 直列六缸、水冷却、增压中冷、柴油发动机。
- 额定功率：194kW/2400rpm。
- 排放标准：符合 III 阶段。
- 油箱容积：350L。

Transmission 变速箱

- Auto-transmission, 6 forward gears and 6 reverse gears, large speed ratio range, adaptable to slope climbing and high-speed traveling.
- 自动变速箱，变速箱有 6 个前进档、6 个后退档，速比范围大，既可满足低速场地爬坡行驶又可满足高速行驶。

Axle 车桥

- Two axle chassis of flexible maneuverability, four-wheel drive, excellent dynamic performance.
- 操控灵活，底盘两桥设计，前、后桥驱动，动力性能好。

Suspension system 悬挂

- The front is rigidly mounted, and the rear axle adopts pivot oscillation suspension with hydraulic lockout.
- 前桥刚性连接，后桥带油缸锁定枢轴摆动悬挂。

Tires 轮胎

- Large diameter off-road 29.5-25 tires deliver large ground clearance and strong off-road agility.
- 大直径越野轮胎，离地间距大，越野性能强，轮胎型号 29.5-25。

Braking 制动系统

- Dual circuit braking system. When one circuit fails, the other can still work normally, improving the safety and reliability of the braking system.
- 双回路制动系统，当某一回路出现故障时，另一回路仍能正常工作，提高制动系统的安全性和可靠性。

Hydraulics 液压系统

- Adopt stable and high-quality main oil pump, enhancing system reliability. Precise parameter matching contributes to superior controllability of the vehicle.
- 采用稳定、高品质的主油泵，系统可靠性高；通过精确的参数匹配，操控性能优越。

Outrigger 支腿

- H-type telescoping outrigger, 4-point support, with span (longitudinal × transverse) 7.52m × 7.6m.
- 采用 H 形伸缩支腿，4 点支撑，纵、横跨距 7.52m × 7.6m。

Control system 控制系统

- CAN-BUS: The bus instrument of integrated intelligent control electrical system can display driving parameters at any time, making driving easier. At the same time, engine failure prompt]makes the maintenance and troubleshooting more convenient and faster.
- All-round safety protection, the main and auxiliary hoists are equipped with three-circle indicators and A2B switches to prevent over-hoist-down and over winding of the wire ropes.
- Load moment indicator: It adopts highly intelligent moment indicator system to fully protect lifting operation and ensure accuracy, stability and comfort.
- 总线仪表：采用集成一体智能控制电气系统的总线仪表，可随时掌控行驾参数，驾乘轻松；同时拥有发动机故障提示功能，维修排故方便、快捷。
- 全方位的安全保护系统，主、副卷扬配置三圈保护器和高度限位器，防止钢丝绳过放和过卷，防倾翻保护，极限角度保护。
- 力 limiter：采用高度智能力矩限制器系统，全方位保护吊载作业，确保操作精准、平稳、舒适。

Crane Introduction

整机介绍

Operator's cab 操纵室

- New generation T-series operator's cab features curved-rail sliding door, safety glass and corrosion resistant steel construction with softened interior trim. Large internal space with panoramic skylight, adjustable seat and other user-friendly design incl. A/C, electric wiper, making it more comfortable and easier to work. The LMI screen is equipped to realize the logic integration of the control console and the display, so that all working data can be seen at a glance.
- 全新一代 T 系列操纵室，带变轨滑移门，配备安全玻璃，耐腐蚀钢板，配置软化内饰、超大内部空间、可调式座椅等人性化设计，配有空调、电动雨刮器，操作更舒适、轻松；配置力矩限制器显示屏，实现主控台与操作显示系统有机结合，使吊装作业的全部工况数据一目了然。

Boom system 臂架系统

- Boom: Five-section, basic boom 12.2m, full-extension 47.5m, made of high-strength welded structural steel with U-shape cross-section.
- Jib: Two-section, 10.2m / 17.5m, offset at 0°, 15°, 30°.
- 主臂：五节臂，基本臂 12.2m，全伸臂 47.5m，由高强度焊接结构钢制成，U 形截面。
- 副臂：两节副臂，分别为 10.2m 和 17.5m，安装角度为 0°，15°，30°。

Slewing platform 转台结构

- SANY independently developed, made of fine grain high strength steel in optimized structure.
- 三一自主设计，结构更优化，由细晶粒高强度钢制成。

Hydraulics 液压系统

- Load sensing variable piston pump can adjust displacement in real time to achieve high precision flow control, greatly reducing energy loss.
- Winch adopts electronically controlled variable motor with high operation efficiency. Max. single rope speed of main and auxiliary winch is 150m/min.
- Slewing system integrating slewing buffer and free swing technology, start & brake process is smoother and the inching motion performance is ever better.
- 采用负载敏感变量柱塞泵，能实时调节油泵排量，实现高精度的流量控制，极大的降低能量损耗。
- 卷扬采用电控变量马达，作业效率高；主、副卷扬单绳速度最大达 150m/min。
- 回转系统带集成回转缓冲阀，具有自由滑转功能，回转启动和控制平稳，微动性卓越。

Hoist 起升机构

- Pump and motor double variable speed regulation, highly efficient and energy saving. Balance valve and unique anti-hook-slip technology are perfectly coupled to achieve smooth rise and fall of the load. Nonrotation high strength wire rope is used.
- 泵、马达双变量调速，高效节能。卷扬平衡阀与独特的防溜钩技术完美结合，重物起落平稳。配备防旋转高强度钢丝绳。

Luffing system 变幅系统

- Double acting single rod hydraulic cylinder with balance valve, luffing angle: -2° ~ 80°. Passive luffing down, reducing energy consumption, improving luffing stability.
- 双作用单活塞杆液压缸，带安全平衡阀，变幅角度：-2°~80°，采用自重落幅系统，降低能耗，提高落幅操作的平稳性。

Slewing 回转系统

- 360° slewing in both directions, max. speed 1.8r/min. It adopts electro proportional speed control for stable movement and system reliability. The unique slewing balance design makes the braking smoother.
- 360° 转动，最大回转速度 1.8r/min。液控比例调速控制，动作稳定，系统可靠。独特的回转缓冲设计，制动更平稳。

Counterweight 配重

- Fixed block 9t.
- 固定配重 9t。

Safety equipment 安全装置

- Load moment indicator: Analytical mechanics is applied and moment limiter calculation system based on the hoisting mechanics model is established. Through online empty-load calibration, the rated accuracy can reach 0~10% to fully protect the hoisting operation. In case of overload, the system will automatically give an alarm to guarantee safety operation.
- The hydraulic system includes balance valve, relief valve, two-way holding valve, etc. to realize system stability and reliability.
- The main and auxiliary winches are equipped with third-wrap indicators to prevent over-hoist-down of the wire rope.
- Boom head and jib head are equipped with A2B switches to prevent the wire rope from over winding.
- The length & angle sensor and pressure sensor are equipped to signify working status in real time, automatically stopping hazardous actions with buzzer alarm.
- 力矩限制器：采用分析力学方法，建立了基于吊重力学模型的力矩限制器计算系统，通过在线空载标定，额定吊重精度达到 0~10%，全方位保护吊装作业；超载作业时，系统自动报警提示，为操纵作业提供安全保障。
- 液压系统配置平衡阀、溢流阀、双向液锁等元件，实现液压系统稳定可靠。
- 主、副卷扬配置三圈保护器，防止钢丝绳过放。
- 主、副臂臂端配置高度限位器，防止钢丝绳过卷。
- 配置长度角度传感器、压力传感器，实时显示起重机作业状态，自动切断危险动作，蜂鸣报警。

Optional equipment at extra fees 选配

- Specialized tires for desert traveling / Slewing buzzer / Navigation beacon / Front towing device / Reversing image / Winch camera / Boom tip camera / Spark arrester / Air intake shutoff valve / Inflator / Outrigger load sensor / other equipment available upon request
- 沙漠胎 / 回转蜂鸣器 / 航标灯 / 前拖钩 / 倒车影像 / 卷扬摄像头 / 臂尖摄像头 / 火星灭火器 / 发动机进气关断阀 / 打气泵 / 支腿压力传感器 / 其他选配视需求定

Operating Range - Telescopic Boom

起升高度曲线 - 主臂

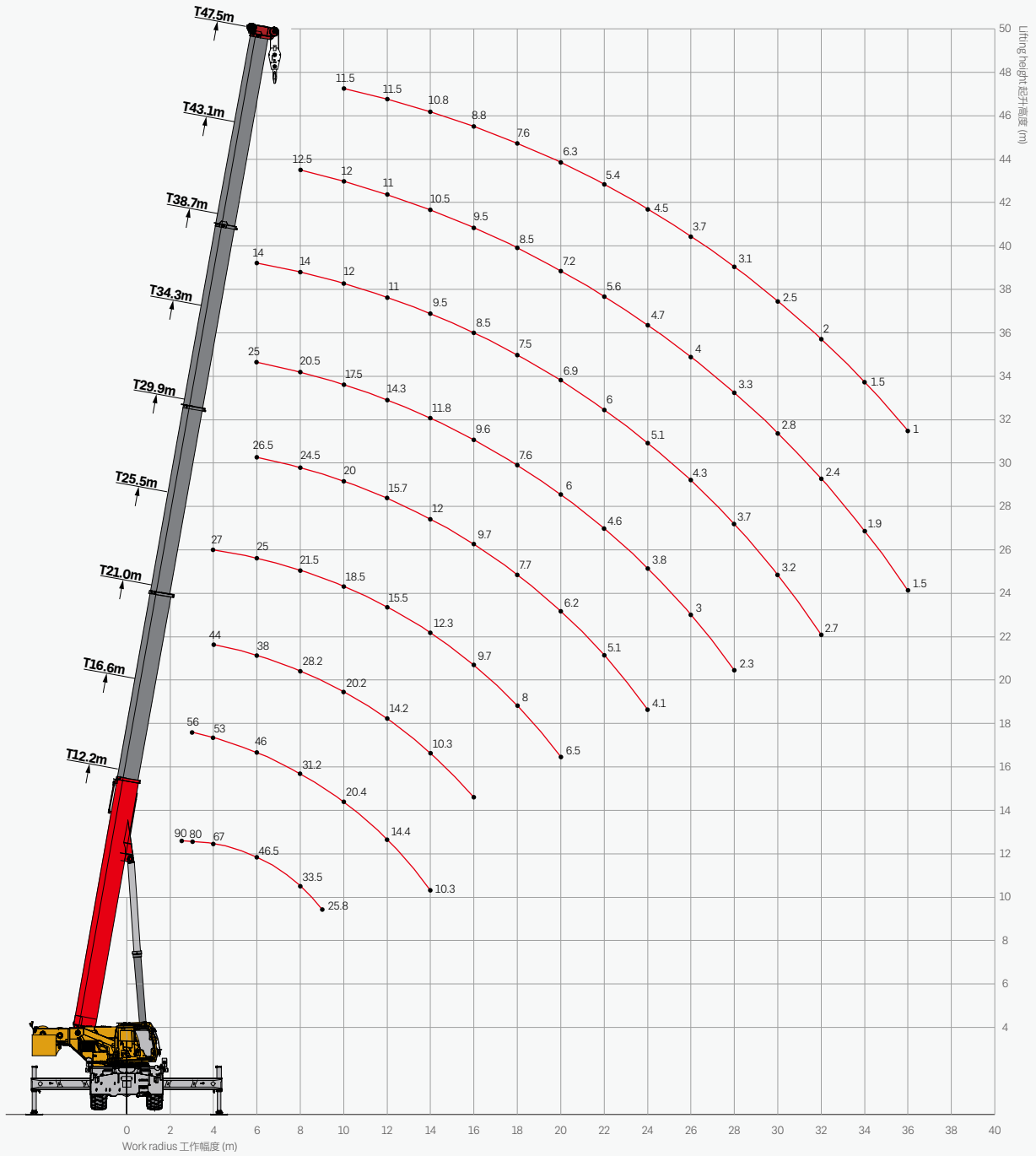

Load Chart-Telescopic Boom

性能表 - 主臂

Unit: kg



Radius (m) 幅度	12.2m	16.6m	18.8m	21.0m	23.2m	25.5m	27.7m	29.9m	32.1m	34.3m	36.5m	38.7m	40.9m	43.1m	47.5m	Radius (m) 幅度
2.5	90000															2.5
3.0	80000	56000	30500													3.0
3.5	74500	54000	30500	44000	30500	27000										3.5
4.0	67000	53000	30500	44000	30500	27000										4.0
4.5	61000	50000	30500	43000	30500	27000	30500	27500	19000	25000						4.5
5.0	55500	47000	30500	41500	30500	27000	30500	27500	19000	25000	18500					5.0
5.5	50500	47000	30000	40000	30000	27000	30000	27500	18500	25000	18500	14000				5.5
6.0	46500	46000	29000	38000	29000	25000	29000	26500	18000	25000	18500	14000				6.0
6.5	42500	42000	28000	35000	28500	24000	28000	26000	18000	24000	18500	14000				6.5
7.0	39000	38500	27000	33500	28000	23000	27000	25500	18000	23000	18500	14000	17000			7.0
7.5	36000	34500	27000	30300	27000	22000	25000	25000	18000	22000	18000	14000	17000			7.5
8.0	33500	31200	26000	28200	26500	21500	23500	24500	17000	20500	17500	14000	17000	12500		8.0
9.0	25800	25000	25000	24200	25000	20000	22500	22500	16000	19300	17000	13000	16000	12000		9.0
10.0		20400	21200	20200	21200	18500	19500	20000	14500	17500	16500	12000	14500	12000	11500	10.0
11.0		16900	17700	17200	17800	17500	16500	18000	13000	15800	15500	11500	13500	11500	11500	11.0
12.0		14400	15200	14200	15200	15500	14000	15700	11800	14300	13500	11000	12500	11000	11500	12.0
14.0		10300	11700	10300	11400	12300	11000	12000	10000	11800	11200	9500	10600	10500	10800	14.0
16.0					8800	9700	8500	9700	8700	9600	9500	8500	8800	9500	8800	16.0
18.0					6700	8000	6600	7700	7600	7600	7700	7500	7800	8500	7600	18.0
20.0						6500	5000	6200	6700	6000	6400	6900	6400	7200	6300	20.0
22.0							3800	5100	5700	4600	5400	6000	5300	5600	5400	22.0
24.0							2800	4100	4800	3800	4300	5100	4300	4700	4500	24.0
26.0									4000	3000	3600	4300	3400	4000	3700	26.0
28.0										2300	2900	3700	2700	3300	3100	28.0
30.0										1700	2400	3200	2100	2800	2500	30.0
32.0												2700	1600	2400	2000	32.0
34.0												2300	1100	1900	1500	34.0
36.0														1500	1000	36.0
38.0														1000		38.0
Telescoping status(%) 伸缩模式																
2nd boom 二节臂	0	50	0	1	50	0	100	50	0	100	50	0	100	50	100	2nd boom 二节臂
3rd boom 三节臂	0	0	25	0	25	50	25	50	75	50	75	100	75	100	100	3rd boom 三节臂
4th boom 四节臂	0	0	25	0	25	50	25	50	75	50	75	100	75	100	100	4th boom 四节臂
Top boom 五节臂	0	0	25	0	25	50	25	50	75	50	75	100	75	100	100	Top boom 五节臂
Rope rate 钢丝绳倍率	12	8	6	6	6	4	6	4	4	4	4	4	4	4	4	Rope rate 钢丝绳倍率
Load at 0° angle 0° 吊载	20000	8000	6000	3000	3000	3000	1000	1500	1500	500	500	1000	-	-	-	Load at 0° angle 0° 吊载

Operating Range - Fixed Jib

起升高度曲线 - 副臂

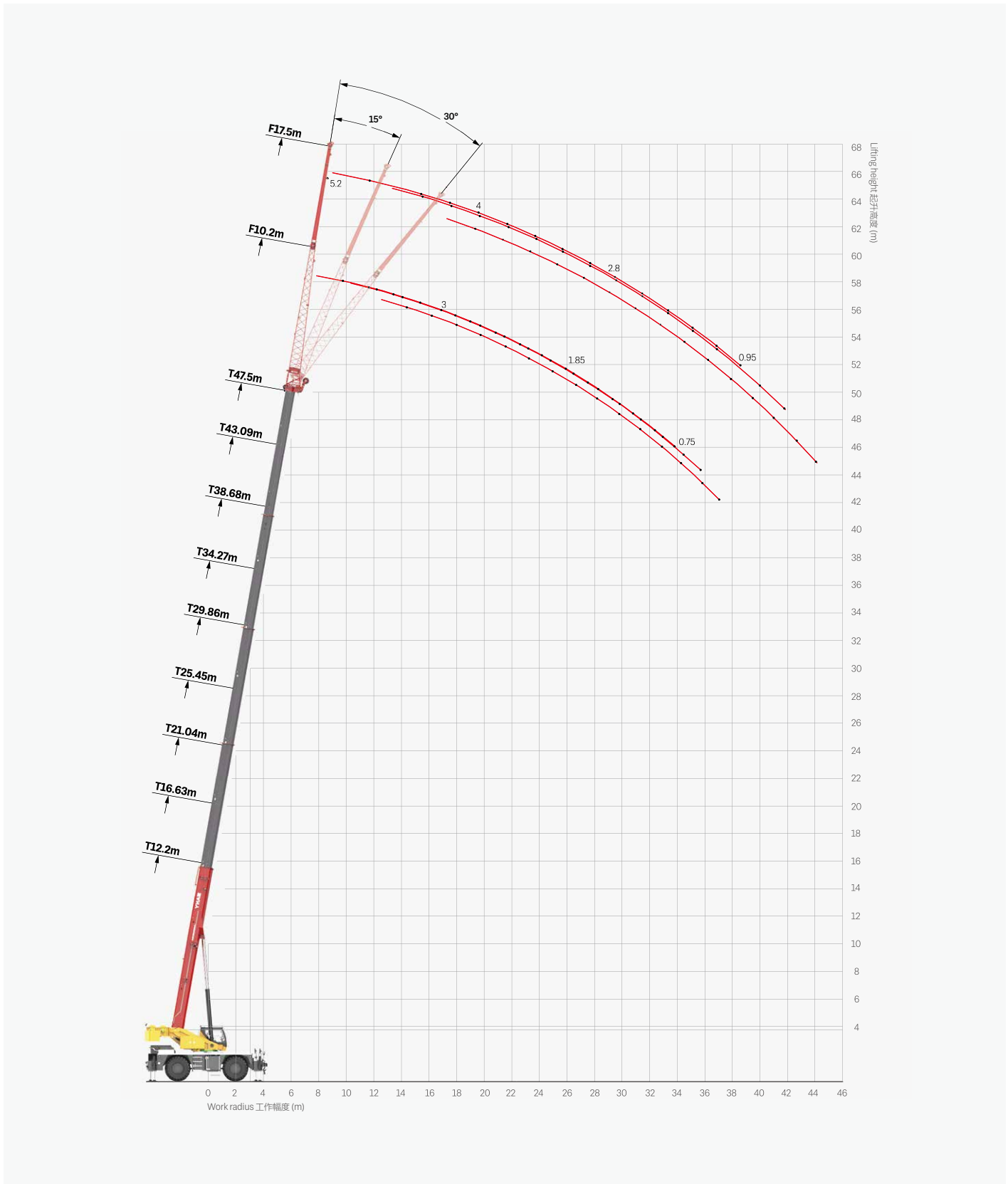

Load Chart - Fixed Jib

性能表 - 副臂

Unit: kg



Boom angle 主臂仰角 (°)	47.5m+10.2m						47.5m+17.5m						Boom angle 主臂仰角 (°)
	0°		15°		30°		0°		15°		30°		
	R (m) 幅度	W (kg) 吊载	R (m) 幅度	W (kg) 吊载	R (m) 幅度	W (kg) 吊载	R (m) 幅度	W (kg) 吊载	R (m) 幅度	W (kg) 吊载	R (m) 幅度	W (kg) 吊载	
80	7.8	5200	10.4	3800	12.6	3300	9.1	3100	13.4	2200	17.3	1500	80
78	9.8	5200	12.3	3700	14.5	3100	11.3	3100	15.6	2100	19.4	1400	78
76	11.8	5000	14.2	3600	16.4	2900	13.5	3100	17.8	2000	21.4	1400	76
74	13.7	4800	16.1	3500	18.2	2700	15.7	3000	19.9	2000	23.5	1400	74
72	15.6	4300	18.0	3300	20.1	2700	17.9	3000	22.0	1900	25.5	1300	72
70	17.5	4000	19.9	3100	21.9	2600	20.0	3000	24.1	1700	27.5	1300	70
68	19.4	3800	21.7	3000	23.6	2500	22.1	3000	26.1	1600	29.4	1300	68
66	21.3	3500	23.5	2900	25.4	2400	24.2	3000	28.1	1500	31.3	1200	66
64	23.1	3200	25.3	2700	27.1	2300	26.3	2750	30.1	1500	33.1	1200	64
62	24.9	3000	27.1	2500	28.7	2200	28.3	2300	32.0	1500	34.9	1100	62
60	26.7	2800	28.8	2300	30.4	2000	30.3	1850	33.9	1400	36.7	1050	60
58	28.4	2300	30.4	2100	32.0	1800	32.2	1600	35.8	1400	38.4	1000	58
56	30.1	1900	32.1	1700	33.5	1700	34.1	1400	37.6	1100	40.1	950	56
54	31.7	1400	33.6	1300	35.0	1200	36.0	1100	39.3	1000	41.7	900	54
52	33.3	1100	35.2	1000	36.5	950	37.8	1000	41.0	850	43.3	800	52
50	34.9	950	36.7	850	37.9	850	39.6	750	42.7	700	44.8	700	50
Min. boom angle (°) 最小仰角	50												Min. boom angle (°) 最小仰角

Load Chart - Telescopic Boom, Pick & Carry, Load Over Front

性能表 - 主臂带载行驶 (正前方)

Unit: kg

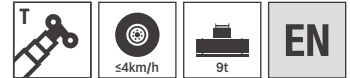

Radius (m) 幅度	12.2m	18.8m	25.5m	Radius (m) 幅度
4.0	19000			4.0
4.5	17000			4.5
5.0	15100	15000		5.0
5.5	13600	14000		5.5
6.0	12400	13000	12000	6.0
6.5	11400	12000	11000	6.5
7.0	10300	11000	10000	7.0
8.0	8500	8800	9000	8.0
9.0	7000	7500	7800	9.0
10.0		6000	6800	10.0
11.0		5000	5800	11.0
12.0		4000	5200	12.0
14.0			4000	14.0
16.0			3200	16.0
18.0			2200	18.0
20.0			1500	20.0
Telescoping status(%) 伸缩模式				
2nd boom 二节臂	0	0	0	2nd boom 二节臂
3rd boom 三节臂	0	25	50	3rd boom 三节臂
4th boom 四节臂	0	25	50	4th boom 四节臂
Top boom 五节臂	0	25	50	Top boom 五节臂
Min. boom angle 最小仰角 (°)	0	0	30	Min. boom angle 最小仰角 (°)
Rope rate 钢丝绳倍率	4	4	4	Rope rate 钢丝绳倍率

Load Chart - Telescopic Boom, On Tires Stationary, Load Over Front

性能表 - 轮胎静止吊载 (正前方)

Unit: kg

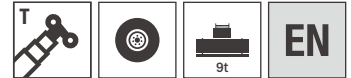

Radius (m) 幅度	12.2m	18.8m	25.5m	Radius (m) 幅度
4.0	21000			4.0
4.5	19000			4.5
5.0	16500	16000		5.0
5.5	15000	14500		5.5
6.0	13500	13000		6.0
6.5	12000	12000		6.5
7.0	11000	11000	11000	7.0
8.0	9000	9200	9500	8.0
9.0	7500	7700	8000	9.0
10.0		6500	7000	10.0
11.0		5500	6000	11.0
12.0		4500	5000	12.0
14.0			4000	14.0
16.0			3000	16.0
18.0			2000	18.0
20.0			1500	20.0
22.0			1000	22.0
Telescoping status(%) 伸缩模式				
2nd boom 二节臂	0	0	0	2nd boom 二节臂
3rd boom 三节臂	0	25	50	3rd boom 三节臂
4th boom 四节臂	0	25	50	4th boom 四节臂
Top boom 五节臂	0	25	50	Top boom 五节臂
Min. boom angle 最小仰角 (°)	0	0	20	Min. boom angle 最小仰角 (°)
Rope rate 钢丝绳倍率	4	4	4	Rope rate 钢丝绳倍率

Load Chart - Telescopic Boom, On Tires Stationary, 360° Slewing

性能表 - 轮胎静止吊载 (360°)

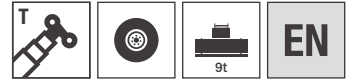

Unit: kg

Radius (m) 幅度	12.2m	18.8m	25.5m	Radius (m) 幅度
4.0	14500			4.0
4.5	11900			4.5
5.0	9400	9500		5.0
5.5	7900	8000		5.5
6.0	6600	6800		6.0
6.5	5500	5800	6500	6.5
7.0	4700	5000	5600	7.0
8.0	3500	4000	4300	8.0
9.0	2500	3000	3400	9.0
10.0		2200	2600	10.0
11.0		1600	2000	11.0
12.0		1000	1500	12.0
14.0			1000	14.0
Telescoping status(%) 伸缩模式				
2nd boom 二节臂	0	0	0	2nd boom 二节臂
3rd boom 三节臂	0	25	50	3rd boom 三节臂
4th boom 四节臂	0	25	50	4th boom 四节臂
Top boom 五节臂	0	25	50	Top boom 五节臂
Min. boom angle 最小仰角 (°)	0	43	52	Min. boom angle 最小仰角 (°)
Rope rate 钢丝绳倍率	4	4	4	Rope rate 钢丝绳倍率



SANY GROUP CRANE BU

SANY Mobile Crane Industrial Park, No.168 Jinzhou Avenue, Jinzhou Development Zone, Changsha City,
Hunan Province, P.R. China Zip 410600
Consulting sanycrane@sanygroup.com (Crane BU) / crd@sany.com.cn (IHQ)
After-sales Service 0086-400 6098 318

Reminder:

Any change in the technical parameters and configuration due to product modification or upgrade may occur without prior notice. The machine in the picture may include additional equipment. This brochure is for reference only, and goods in kind shall prevail.

Copyright at SANY. No part of this brochure may be copied or used for any purpose without written approval from SANY.

© Edited in July 2022

三一集团起重事业部

中国湖南长沙金洲开发区金洲大道 168 号 三一汽车起重机产业园 邮编: 410600
咨询: sanycrane@sanygroup.com (起重事业部) / crd@sany.com.cn (国际总部)
海外售后服务: 0086-400 6098 318

温馨提示:

由于技术不断更新, 技术参数及配置如有更改, 恕不另行通知。图中机器可能包括附加设备, 本画册仅供参考, 以实物为准。
版权为三一所有, 未经三一书面许可, 本画册任何内容不得被复制用于任何目的。

© 2022 年 7 月版

